

384 924 GB

Lenze

Operating instructions

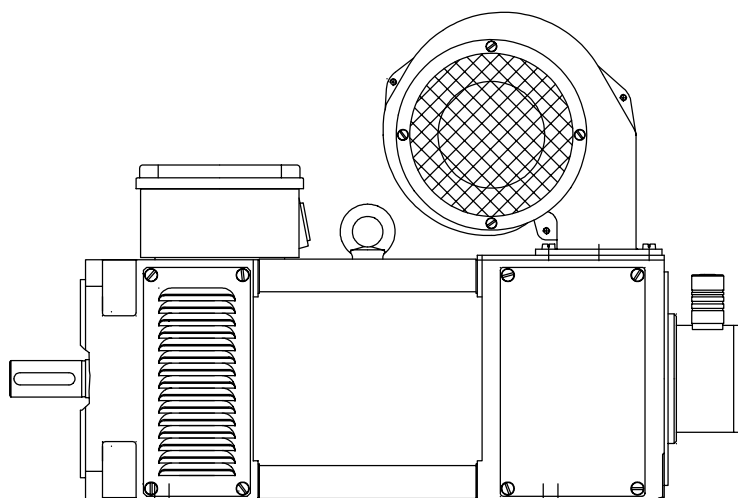
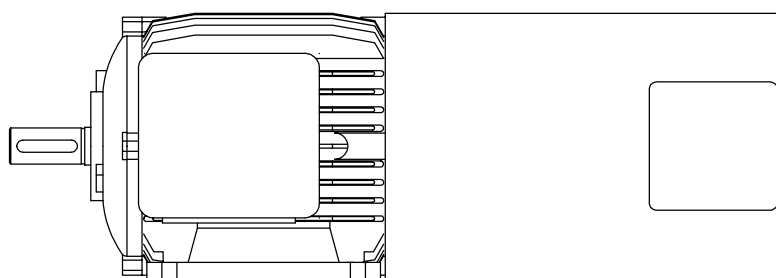

DC shunt motors

Type **MGXRK 090 ... 160**

MGXQU 080 ... 160

MGXQK 063 ... 160



Copyright Lenze GmbH & Co KG, Postfach 101352, D-31763 Hameln

First read operating instructions, then act !

Manufacturer:

Lenze GmbH & Co KG
Postfach 101352
D-31763 Hameln

Location:

Aerzen
Hans-Lenze-Straße 1
D-31855 Aerzen
Tel.: (05154) 82-0
Fax : (05154) 82-4040

Country of origin and year of construction:

See nameplate (chapter 4.4)

These Operating instructions are valid for DC shunt motors of the series:

- **MGXRK 090 ... 160**
- **MGXQU 080 ... 160**
- **MGXQK 063 ... 160**

BA 13.0005
Author: Motor Division
2nd edition 06/97

Contents	Page
1. Explanation of symbols	4
2. General safety notes	4
2.1 Users	4
2.2 Safety notes	4
3. Transport and storage	4
3.1 Unpacking	4
3.2 Transport within the site of installation	4
3.3 Conditions of storage	4
3.4 Waste disposal of the packing material	4
4. Product description	5
4.1 Function description	5
4.2 Area of application	5
4.2.1 Other areas of application	5
4.3 Type code	6
4.4 Designation / Nameplate	7
4.5 Technical data	7
4.6 Emissions	8
5. Assembly / Installation	9
5.1 Preparations	9
5.2 Site of installation, nominal conditions, and influencing factors	9
5.3 Installation	9
5.4 Electrical connection	9
5.5 Parts for attachment	11
6. Commissioning and operation	12
6.1 Checking before commissioning	12
6.1.1 Measuring the insulation resistance	12
6.2 Function test	13
6.3 Inspection	13
6.4 Fault - Cause - Remedy	14
7. Maintenance / Repair	15
7.1 Maintenance periods	15
7.2 Wear check of carbon brushes	15
7.3 Wear check of the collector	17
7.4 Recognition of incorrect operating conditions	18
7.5 Waste disposal of the product	19
8. Spare parts	20
8.1 Spare parts lists	20
8.2 Ordering example for spare parts	22
Manufacturer's Declaration	
Service addresses	



1. Explanation of symbols

Danger !

General danger (Danger of persons and/or material)



Use in hazardous areas is prohibited.



Dangerous electrical voltage.



High temperature.



Assembly or dismantling using hammers or other striking tools is prohibited.



Note: Use raw material for recycling.

2. General safety notes

First read, then act !



2.1 Users

Assembly, commissioning, operation, and maintenance only by specialists or skilled personnel.

2.2 Safety notes

△ Read operating instructions before assembly, commissioning, operation, and maintenance.

△ Observe safety notes and warning symbols in the individual chapters.

△ Observe regulations for safety and prevention of accidents.

△ Do not operate in hazardous areas !

△ Only intended use is permissible.

△ For non-intended use and non-authorized modifications, the product liability and warranty are invalid.

3. Transport and storage

3.1 Unpacking

- Take drive components out of the packing and check for transport damages.
- Check if the shipment is complete.

3.2 Transport within the site of installation

- Transport motors only with sufficiently strong transportation tools or hoists. Ensure safe fixing.

Some of the motors are equipped with eyebolts for a safe fixing at the hoists (for weights see chapter 4.5).

- Transport motors vibration-free
- Avoid strong shocks and impacts

3.3 Conditions of storage

- Location of storage:

- vibration-free

If there is a risk of vibration, it is recommended to rotate the rotor in its bearings once a week.

- dry without aggressive media

- no dust

- no fast temperature changes

- Corrosion:

- steel parts are protected against corrosion by the factory. Do not remove this protection, check in intervals of approx. three months and renew, if necessary.

In case of intermediate storage > 3 months

- Collector:

- take off carbon brushes from the collector surface

- protect collector by a piece of paper around the running surface.

3.4 Waste disposal of the packing material

△ Packing material can be recycled.

3.4



4. Product description

4.1 Function description

The motors of the MGXRK, MGXQU and MGXQK series are separately excited DC shunt motors.

The motors of the MGXRK series are surface-cooled in IP54 enclosure and have a round, ribbed housing. The motors of the MGXQU and MGXQK series have a square cross-section, are designed in IP23S enclosure and internally ventilated.

The motors have fully-laminated stators and are externally cooled by axially or radially mounted blowers in their standard design (type GF...). With reduced power, the motors are also supplied with speed-dependent self-ventilation (type GE...) and without ventilation in self-cooled design (type GS...).

4.2 Area of application

△ Do not use in hazardous areas !

△ Fire risk !

Avoid contact with inflammable material !

- Ambient temperature must be up to +40 5C, higher ambient temperature require a power reduction.
- Installation height up to 1000 m above sea level, installation above 1000 m above sea level requires a power reduction.
- Observe temperature class F (155 5C) according to DIN-IEC 34 / VDE 0530. If the limit temperature is exceeded, the insulation is weakened and damaged.
- Enclosure to DIN-IEC 34 is IP54 or IP23S. The actual enclosure can be obtained from the nameplate (see chapter 4.4.)
- No tropical insulation.
- Designs (to DIN-IEC 34 part 7)
MGXRK: IM B3, IM B5, IM B14
MGXQU, MGXQK: IM B35 and IM B34

The motors can be mounted in any mounting position. Vertical arrangements according to DIN-IEC 34 part 7 are possible.

4.2.1 Other areas of application

- For other areas of application a power or torque reduction is required using the factors of the following table.

The permissible continuous power is calculated from:

$$P' = k_J \cdot k_h \cdot P_d$$

with P_d being the permissible continuous torque under normal conditions.

The torque can be calculated accordingly:

$$M' = k_J \cdot k_h \cdot M_d$$

M_d being the permissible continuous torque under normal conditions.

Cooling air temperature 5C	40	45	50	55	60
Power reduction k_J	1.00	0.95	0.90	0.83	0.77

Power reduction with different ambient or cooling air temperature

Installation height above sea level in m	1000	2000	3000	4000	5000
Power reduction k_h	1.00	0.92	0.83	0.77	0.67

Power reduction with different installation height

- If the actual form factor $F_F^* \geq 1.05$, a power reduction or torque reduction is also required.

The permissible continuous load is calculated from:

$$P' = (1.05 / F_F^*) \cdot P_d$$

The torque is calculated as follows:

$$M' = (1.05 / F_F^*) \cdot M_d$$

The form factor can be improved, among others, by using armature chokes. Armature chokes which are suitable for Lenze controllers can be obtained from the technical descriptions of the controllers or from your nearest Lenze representative.



4.3 Type code

MGXXX XX XXX - XX

Motor

Current type

MG = DC current

Cooling / Ventilation

F = forced-ventilated

E = self-ventilated (cooling effect depends on the speed)

S = natural cooling (cooling by convection and radiation)

Design / Housing

Q = Smooth housing, square

R = Ribbed housing, round

Type of machine

K = compensated

U = not compensated

Attachments

BI = Brake and pulse encoder

BR = Brake

BS = Brake and resolver

BT = Brake and tacho

BU = Brake + Tacho + pulse encode

IG = Pulse encoder

RS = Resolver

TA = Tacho, analog sensor

TI = Tacho + pulse encoder

XX = no attachments

Size

Axis height in IM B3 design in mm

Length

0 = VS very short

1 = S short

2 = M middle

3 = L long

4 = VL very long

Pole pair numbe

1 = p=1 (2-pole)

2 = p=2 (4-pole)

4.4 Designation / Nameplate

The nameplate consists of the following data (tolerances according to DIN-IEC 34):

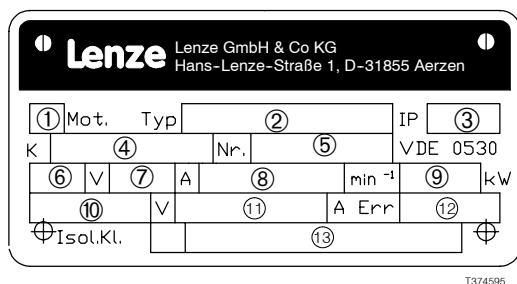

- ① Motor type (G for DC shunt motor)
- ② Motor type of the form MGXXXXX XXX - XX
- ③ Enclosure
- ④ Commission number, including year of construction
- ⑤ Motor number
- ⑥ Rated armature voltage
- ⑦ Rated armature current
- ⑧ Rated speed
- ⑨ Rated power
- ⑩ Rated excitation voltage
- ⑪ Rated excitation current
- ⑫ Temperature class
- ⑬ Attachments (B-side)

4.5 Technical data

The rated powers indicated on the nameplate are based on a form factor of the armature current of $F_F = I_{eff} / I_{arithm.} = 1.05$. With higher form factors a power reduction according to chapter 4.2.1 is required.

In the following, the technical ratings and main dimensions (overall dimensions) of the standard motors without B-side attachments with separate blower and with filter element are listed.

Table 1: Technical data of MGFRK standard motors (without B-side attachments) :

Motor size	M_N Nm	J kgm ²	F_r N	F_a N	$F_{r,v}$ N	Weight kg	L mm	W mm	H mm
MGFRK 090-22	5.8	0.0040	780	440	2100	21	492	253	200
MGFRK 100-22	8.9	0.0061	1000	500	2700	28	530	284	250
MGFRK 112-22	15.5	0.0142	1500	500	2800	40	538	298	280
MGFRK 132-22	32.5	0.0411	2200	1100	4500	84	709	354	325
MGFRK 160-32	73.7	0.1120	3000	1250	5100	172	941	406	376

Table 2: Technical data MGFQU standard motors (without B-side attachments) :

Motor size	M_N Nm	J kgm ²	F_r N	F_a N	$F_{r,v}$ N	Weight kg	L mm	W mm	H mm
MGFQU 080-22	18.3	0.0087	1200	400	1950	36	467	235	335
MGFQU 100-22	36.1	0.0237	1600	580	3100	65	520	235	375
MGFQU 112-22	73.8	0.0475	2300	1000	4900	115	660	259	451
MGFQU 132-32	140.5	0.1120	2300	1350	4900	170	760	275	525
MGFQU 160-22	279.0	0.2452	4950	3580	9700	250	864	508	606
MGFQU 160-32	343.0	0.3200	5050	3580	9900	285	944	508	606

Tab. 3: Technical data of MGFQK standard motors (without B-side attachments) :

Motor size	M_N Nm	J kgm ²	F_r N	F_a N	$F_{r,v}$ N	Weight kg	L mm	W mm	H mm
MGFQK 063-32	7.0	0.0032	750	400	1100	19	451	235	299
MGFQK 100-32	34.3	0.0170	1600	580	3100	65	520	247	427
MGFQK 160-22	289	0.2452	4950	3580	9700	250	864	508	606
MGFQK 160-32	356	0.3200	5050	3580	9900	285	944	508	606

The torques and weights indicated in the tables are only considered to be guidelines for the dimensioning and bases.

The actual technical data must be obtained from the nameplate of your motor (see chapter 4.4).

Signs:

- M_N = Rated torque
 J = Inertia
 F_r = Permissible radial load
 F_a = Permissible axial load
 $F_{r,v}$ = Permissible radial load with reinforced bearing
Gew. = Motor weight (incl. blower)
 L = Motor length
 H = Motor height
 W = Motor width
- The permissible loads mentioned in table 1 to 3 are understood to be either radial loads or axial loads.

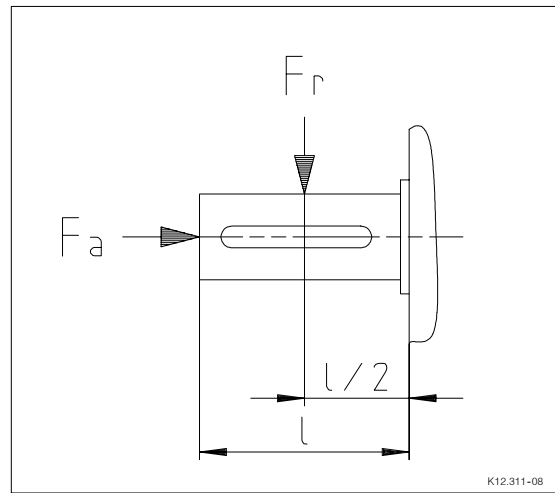

Fig.1: Point of application of radial and axial loads

4.6 Emissions

△ Risk of burning !

The surface temperature of the motors can be up to 90°C depending on the operating state.

• Noises:

The noise level of 70 dB(A) is not exceeded by the following motors:

MGFRK 090-22

MGFRK 100-22

MGFQU 080-22

MGFQK 063-32

Noise level of the other motors:

Motor type	Noise level dB(A)
MGFRK 112-22	75
MGFRK 132-22	76
MGFRK 160-32	78
MGFQU 100-22	76
MGFQU 112-22	81
MGFQU 132-32	83
MGFQU 160-22	86
MGFQU 160-32	86
MGFQK 100-32	76
MGFQK 160-22	86
MGFQK 160-32	86

• Dusts :

Scuff of carbon brushes inside the motor with enclosed motors,
in the outlet air of enclosed-ventilated motors.

Composites:

- different metals
- graphite
- possibly epoxy resin or other bonding agents



5. Assembly / Installation

5.1 Preparations

- Unpack motors and check for transport damages.
- If necessary, remove fastening device of the key and residuals of the corrosion protection.
- The motors were checked at the factory and are ready for use.

5.2 Site of installation, nominal conditions, and influencing factors

△ Do not operate in hazardous areas !

The motors are designed for the following nominal conditions:

- Supply with half- or fully controlled bridge rectifier
- Rated power is based on a current form factor of

$$F_F = I_{\text{eff}} / I_{\text{arithm.}} = 1.05$$
 (see chapter 4.2.1)
- Ambient or cooling air temperature up to +40 °C (see chapter 4.2.1)
- Installation height up to 1000 m above sea level (see chapter 4.2.1)
- Operation within the permissible control range or self-ventilated motors
- Ensure unimpeded flow of incoming and outgoing air
- Avoid re-circulating of warm outlet air by the motor

5.3 Installation

△ Ensure that no foreign matter penetrates into the motor during assembly and commissioning!

- Prepare fixing according to the design, weight, and torque of the motor.
- Before fixing the motor, the foot and flange faces must evenly rest on. Insufficient alignment of the motors reduces the life of the bearings and transmission elements!

△ Assembly of clutches and other transmission elements according to the instructions. To prevent damage of the bearings, avoid under all circumstances impacts on shafts and exceeding of the permissible radial and axial forces!

- Ensure sufficient space for unimpeded maintenance.

5.4 Electrical connection

△ Make electrical connections only when no voltage is applied! Danger of unintended startings or electrical shocks.

△ Electrical connections must only be made by skilled personnel.

- Operate DC shunt motors only at DC voltage. The supply is normally via DC speed controllers. Make sure that the supply voltage / controller output voltage is identical with the nameplate data.
- A separate blower, which may be connected, requires a single-phase or three-phase AC voltage according to the nameplate.
- A spring-loaded brake, which may be attached, requires a suitable DC voltage or an AC voltage which corresponds to the connected rectifier.
- Dimension the connecting cables sufficiently large to avoid a non-permissible heating.

current [A]	≤ 6	≤ 10	≤ 16	≤ 20	≤ 25	≤ 35	≤ 50
Cable cross-section [mm ²]	0.75	1	1.5	2.5	4	6	10

Rated current in [A]	≤ 63	≤ 80	≤ 100	≤ 125	≤ 160	≤ 200	≤ 250
Cable cross-section in [mm ²]	16	25	35	50	70	95	120

When the cables are very long, select a cross-section one size larger to reduce losses.

- The motor cable cannot be protected by the thermal sensors of the motor winding. Provide measures according to DIN 57100 / VDE 0530.
- Make electrical connection according to the connecting diagram which is attached to every motor. The connecting diagrams for the standard factory design are shown in fig. 2 and fig. 3.



5.2



5.3



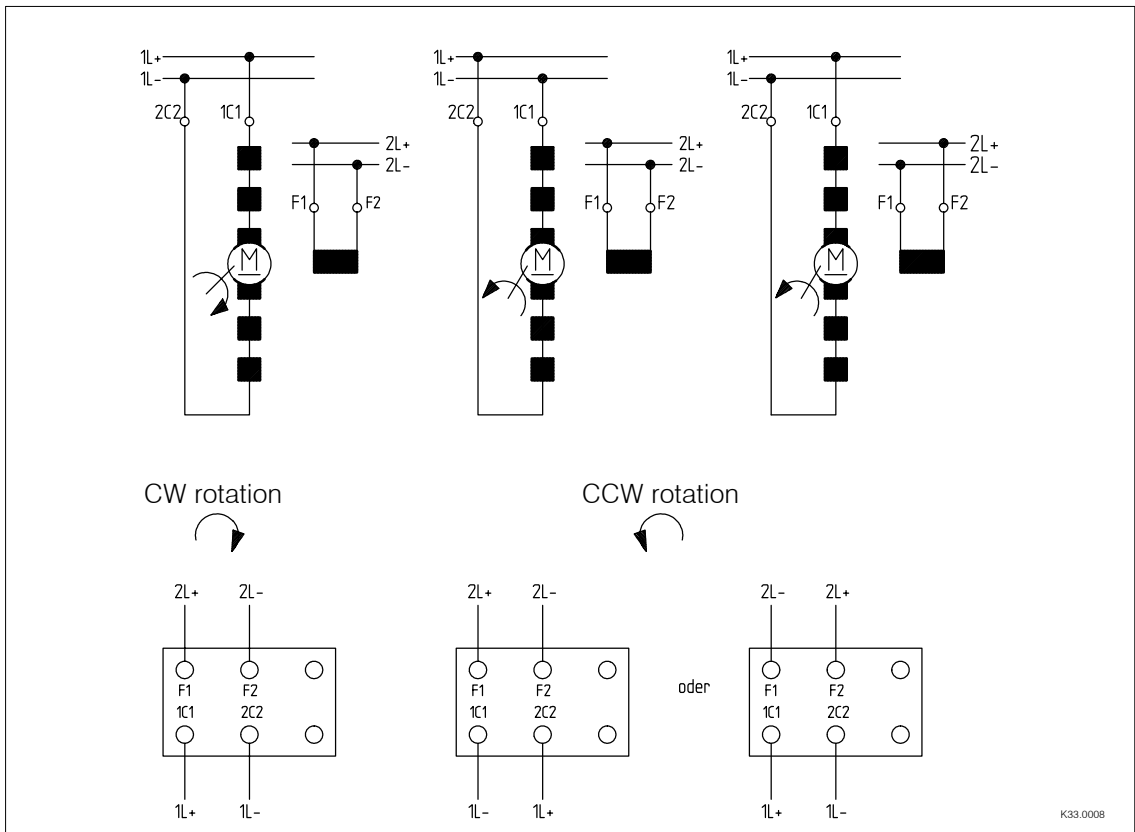

Fig. 2: Motor connecting diagram for the motor types MGFRK, MGERK, MGSRK, MGFQK, MGEQK, MGSQK (compensated design with commutating pole winding)

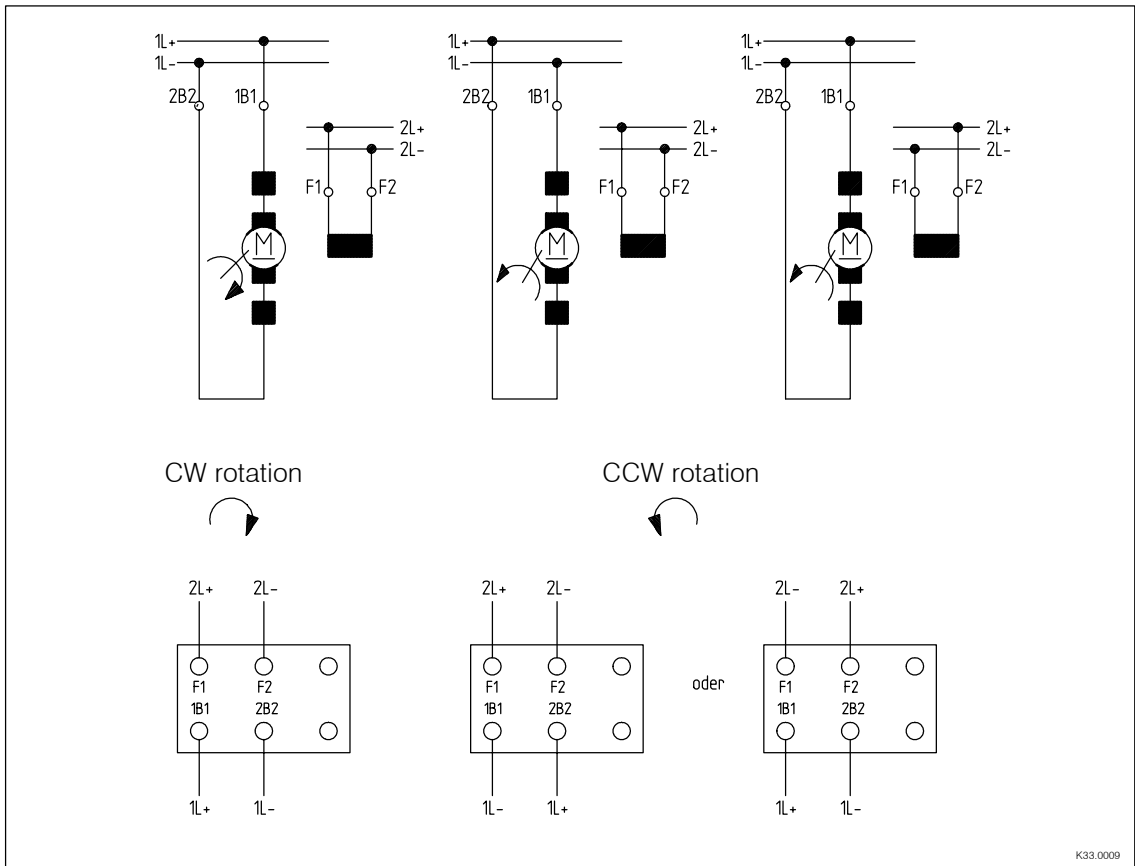

Fig. 3: Motor connecting diagram for the motor types MGFQU, MGEQU, MGSQU (uncompensated design with commutating pole winding)

5.5 Parts for attachment

- △ Attach parts to the drive only when no voltage is applied!
- △ Remove loads from the motor or secure loads acting on the drive!
- △ Do not use hammers or other impact tools for assembly and dismantling!

- Motors with B-side attachments (brakes and/or feedback sources) are assembled, electrically connected and checked for their function. Observe suitable operating instructions.
- When brakes and/or feedback sources are retrofitted, observe the following connecting designations for additional devices and attachments, the suitable installation instructions and operating instructions.



Connecting designations of additional devices and attachments to the terminal board or terminal strips

Attachments		Terminal	Connection
Protective earth (SL) Ground			
External blower 1 ~		U1 U2	Connection to L1 - mains Connection to N - mains
External blower 3 ~		U1 V1 W1	Connection to L1 - mains Observe direction of rotation! Connection to L2 - mains Interchange Connection to L3 - mains L1 - L2 in case of incorrect rotation
DC tacho	+ -	2A1 2A2	Polarity with CW rotation
AC tacho with rectifier	+ -	3A1 3A2	Polarity independent of the direction of rotation
Thermal contact (normally closed)	max. 250V ~ max. 1.6 A ~	S1 S2	Warning 1S1 switch-off 2S1 Warning 1S2 switch-off 2S2
Thermal contact (normally open)	max. 250V ~ max. 1.6 A ~	S3 S4	Warning 1S3 switch-off 2S3 Warning 1S4 switch-off 2S4
PTC		P1 P2	Warning 1P1 switch-off 2P1 Warning 1P2 switch-off 2P2
Brake DC excitation	+ -	Y1 Y2	
Brake rectifier		1 4 2+ 3-	Connection to L1 - mains Connection to N - mains Connection to brake Y1 (+) Connection to brake Y2 (-)
Brush indicator (normally closed)	Max. 28 V - max. 4 A -	1H1 1H2	isolated
Brush indicator (normally open)	Max. 28 V - max. 4 A -	1H3 1H4	isolated
Brush indicator (normally closed)	Max. 28 V - max. 4 A -	2H3 2H4	not isolated 1st indication circuit
Brush indicator (normally open)	Max. 28 V - max. 4 A -	3H3 3H4	not isolated 1st indication circuit
Standstill heating		E1 E2	24 V
Standstill heating		E3 E4	230V
Pulse encoder	Supply + Supply - Output channel A Output channel A Output channel B Output channel B Output channel C Output channel C Earth Screen Analog output	B1 B2 B3 B4 B5 B6 B7 B8 B9 B10 B11	Supply GND (ground) Inverse Inverse Zero track Inverse
Resolver		-	Connection via system cable, connecting diagrams are attached to the drive

6. Commissioning and operation



- △ Do not operate in hazardous areas!
- △ Depending on the operating state, the surface temperature can exceed 90 °C. Keep cooling times!
Do not touch motor surface if drives are in operation!
Provide protection against skin contact if necessary!
- △ Fire risk! Do not spray or clean drives with inflammable detergents or solvents!
- △ Avoid overheat!
Deposits on drives obstruct the required heat dissipation and must be removed in intervals.

6.1 Checking before commissioning

- △ Check the drive only when no voltage is applied!

Check the following items before

- the first commissioning
- commissioning after a long period standstill
- commissioning after maintenance of the motor
 - firm connection of the screws of the mechanical and electrical parts
 - completeness of the set of carbon brushes
 - easy sliding of the carbon brushes in the brush holders
 - contact of all brush holder springs on the carbons
 - if an oxide layer has deposited on the collector surface:
Grind using a collector hand finishing stick or a corundum brick. Never use solvents for cleaning.
 - brush in "neutral position" (coloured mark at the brush yoke and at the endshield must coincide)
 - sufficient insulation resistance (see chapter 6.1.1)
 - unimpeded inlet and outlet of cooling air
 - efficiency of the protections against overheat (checking the thermal sensors)
 - direction of rotation of the separate blower

6.1.1 Measuring the insulation resistance

- To measure the insulation resistance, disconnect the connecting cables. Earth the winding parts which are not to be checked and the thermal sensor.
- Check the following insulation resistances:
 - across rotor and stator windings
 - across brush rulers with lifted brushes and across earth
- Test voltage:
highest rated motor voltage or 500 V
- Test temperature:
test motor housing for ambient temperature

Minimum insulation resistances:

- **New motor:**

The insulation resistance in kW must be at least as high as the highest rated motor voltage. Example:

$$U_A = 460 \text{ V}; U_f = 360 \text{ V} \\ \Rightarrow \text{insulation resistance } R_I \geq 460 \text{ kW}$$

When the resistance is smaller, dry the motor before commissioning.

- **Recommissioning:**

The insulation resistance of a motor which had been in operation already, must be at least 50 kW.

When the resistance is smaller, clean the windings and the area of the collector and brushes. After a long period of standstill, an additional drying may be necessary.

Possible procedure for drying:

1. Use a blower to blow dry, warm air of 80 °C from the B-side through the motor. If possible, slowly rotate the rotor.
2. Allow housing to cool to ambient temperature
3. Measure insulation resistance
4. Repeat drying procedure until the insulation resistance has obtained the required value.



6.2 Function test

Caution !

Apply armature voltage only when excitation voltage is applied!

When the voltage is applied without an excitation voltage being applied to the motor, the motor may be destroyed due to overspeed, i.e. the motor speed may rise until the rotor is destroyed.

- Commission the drives and check all individual functions, such as
 - torque behaviour and current consumption
 - braking of the attached brake
 - output signal of the feedback system
- in case of malfunctions or interferences: trouble-shooting according to chapter 6.4.

6.3 Inspection

- We recommend to inspect drives in operation every 50 operating hours. Observe:
 - loud noises
 - excessive surface temperatures
 - oily drive parts or leakages
 - changed speeds etc.
- In case of irregularities: see trouble-shooting chapter 6.4.





6.4 Fault - Cause - Remedy

- △ Maintain and repair the drive only when no voltage is applied!
- △ High temperatures of the motor surfaces. Keep cooling times!
- △ Remove loads from the motor or secure loads acting on the drive!

Interferences

Fault	Cause	Remedy
Motor does not start	Power supply interrupted	Check electrical connection (chapter 5.4)
	Controller inhibited	Check controller display, check controller enable
	No carbon brushes or not correctly installed	Check if brush set complete and placed correctly (chapter 7.1)
	Armature coils defective or short-circuited	Remove short circuit (often only possible is a special workshop or by the manufacturer)
	Excitation winding interrupted	Remove interruption
Motor does not start (high current consumption)	Brake does not release	Check electrical connection
		Check air gap 's _{Li} ' (see operating instructions of the brake)
		Magnetspule überprüfen
	Drive is blocking	Check for free running of components (remove foreign matter, if necessary)
Surface temperature > 90 5C	Overload of the drive	Check current consumption, check load and reduce, if necessary
	Heat dissipation obstructed by deposits	Clean surface of the drive
	Cooling ducts inside the motor are obstructed by deposits	Remove deposits inside the motor
Motor suddenly stops and does not start again	Thermal contact interrupts power supply	Reduce load, allow motor to cool (for cleaning see above)
		Check cooling effect (direction of rotation) of the separate blower
		Clean or replace filter element of the separate blower
Uneven running, motor stops for a short time	Carbon brushes are worn	Replace brush set (chapter 7.1)
	Carbon brushes are jamming, abrasive matter in the guidance	Cleaning of the inner part (chapter 7.1)
	Winding contact in the armature windings	Repair in the workshop or by the manufacturer
	Bar contact at the collector	Check collector and remove contact between the bars
Uneven running (vibrations)	Insufficient balancing of coupling elements or working machine	Rebalancing
	Insufficient alignment of the drive train	Re-align machine set, check base, if necessary
	Fixing screws are not tightened	Check screw connections and secure
Excessive speed, motor oscillates under load	Brush yoke shifted from the neutral zone	Coincide colour label at the brush yoke and endshield
	Interference of excitation current circuit	Check excitation current and voltage, eliminate cause of interference
Noise	Carbon brushes are not run-in	Support run-in (chapter 7.1)
	Foreign matter inside the motor	Cleaning of the inside area of the motor, repair by manufacturer, if necessary
	Bearings damaged	Replace bearings, repair by manufacturer, if necessary

7. Maintenance / Repair

- △ Maintain and repair the drive only when no voltage is applied !
Disconnect drive from the power supply!
- △ High temperatures of the motor surfaces.
Keep cooling times!
- △ Remove loads from the motor or secure loads acting on the drive!
- △ Make sure that no foreign matter penetrates inside the motor during maintenance and repair!

7.1 Maintenance periods

Carbon brushes and in some cases also collectors are wear parts in commutator machines.

- Service intervals:
Since the abrasion of the carbon brushes strongly depends on the operating conditions, we recommend the following intervals for checking:
 - 1st check after approx. 100 operating hours
 - 2nd check after 300 more operating hours
 - further tests depending on the wear which has been found. For safety reasons, the service intervals should not exceed 1000 operating hours.

7.2 Wear check of carbon brushes

- To remove the brushes the brush yoke of some motors must be disconnected and rotated. The correct position of the brush yoke (neutral zone!) is marked by a colour mark at the brush yoke and the endshield. This mark must exactly coincide after inspection or replacement of the brushes.
- We recommend to write down the measured brush length.
- Check the quality and the appearance of the running surface of collector and carbon brush, especially during the first check:
 - A homogenous film (patina) must have deposited on the collector running surface.
 - The running surface of the carbon brushes must be even and must not show any "blushings", burnings or broken edges.
 - If the result of the inspection is not satisfactory, you can refer to chapter 7.4, find possible causes and eliminate them. In case of doubt, please contact the Lenze Service.



Checking and replacing carbon brushes

1. For MGXRK series:
Dismantle blower hood and tightening strap.
For MGXQU series:
Dismantle cover sheets at the B-side endshield.
2. Loosen carbon abrasion inside the motor using a brush and suck off.
Do not blow out, because the dust may be blown inside the motor and in the winding heads.
3. Take off spring of the brush holder, take out carbon brushes and measure the length of the brushes:
 - The carbon brushes are marked with letters. The lower edge of the letters is the wear limit.
 - If this limit is almost reached, always replace the carbon brushes in sets. Only use genuine carbon brushes or those approved by the manufacturer, otherwise the commutation and brush life are endangered (for orders see chapter 8.2).
4. Insert carbon brushes such that they easily slide in the brush holders.
Place the wires such that the carbons can slide without being obstructed, when they are shortened due to wear.
5. To ensure a good electrical contact between carbon brushes and collector, grind the carbon brushes such that they are adapted to the collector diameter before the motor is commissioned:
 - For motors which have free access to the shaft ends and where the rotors can easily be rotated by hand (fig. 4, sketch 1):
Fix abrasive paper or abrasive cloth of grain 180 or hold by hand.
Insert the new carbon brushes and place spring of the brush holder on the carbon brushes.
Then turn the rotor of the motor to both sides until the contact surface of the carbon brushes has completely adapted to the running surface diameter of the collector.
 - For heavy motors which are difficult to move and those motors the shafts ends of which are not accessible, the carbon brushes of each pole must be ground separately (fig. 4, sketch 2):
Lay a strip of abrasive paper or abrasive cloth of grain 180, the length of which corresponds to the length of the collector running surface, between the running surface and the brush holders of a pole.

Insert the new carbon brushes and place the spring on the carbon brushes.

By moving the abrasive paper under the carbon brushes to both sides along the collector shape, grind all carbon brushes of a pole at the same time.

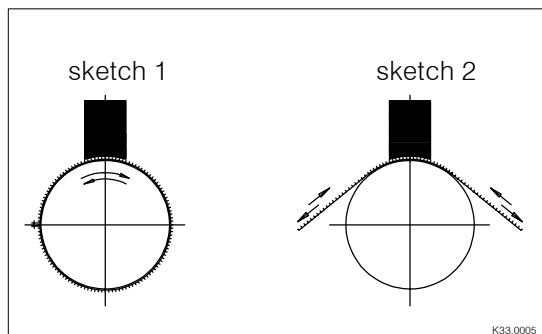

Fig. 4: Grinding of carbon brushes

6. Take carbon brushes out of the brush holders. Carefully remove grinding and carbon dust.
7. Insert carbon brushes again.
8. After disconnecting and turning the brush yoke:
 - Set "neutral zone" again. For this, the mark at the brush yoke and the endshield must exactly coincide. Reconnect brush yoke.
9. For MGXRK series:
Reassemble tightening strap and blower hood.
For MGXQU series:
Reassemble cover sheets.

The motor is now ready to operate again.

7.3 Wear check of the collector

- Under normal operating conditions, the collector does not need special maintenance.
Normally, the collector must only be machined after several sets of carbon brushes have been used.
- In case of strong ovality or clear burns, the collector must be ground or dressed, if necessary. Normally a slight regrinding using a collector finishing stick, which is adapted to the shape of the collector running surface, is sufficient.

Dress the collector when:

- the collector running surface shows clear chatter marks
 - the collector shows marks in the carbon brush running surfaces of more than 0.3 mm depth
 - the collector running surface is oval for more than 0.015 mm
For even ovality of the running surface, an ovality of 0.03 mm is acceptable during operation.
 - the height (difference of the radius) between two bars next to each other is more than 2 mm
 - there are strong burns at the bars or bar edge
- The following minimum diameter of the collector running surfaces must not be exceeded, otherwise a perfect operation is not ensured.

Motor type	Diameter of the collector running surfaces mm	
	new	minimum
MGXPK 090-22	68.0	66.0
MGXPK 100-22	75.5	74.0
MGXPK 112-22	84.0	82.0
MGXPK 132-22	111.0	108.0
MGXPK 160-32	137.0	134.0
MGXQU 080-22	81.5	79.0
MGXQU 100-22	91.3	90.0
MGXQU 112-22	104.0	102.0
MGXQU 132-32	137.0	134.0
MGXQU 160-22	150.0	147.0
MGXQU 160-32	150.0	147.0
MGXQK 063-32	64.0	62.0
MGXQK 100-22	94.6	92.2
MGXQK 100-32	94.6	92.2
MGXQK 160-22	150.0	147.0
MGXQK 160-32	150.0	147.0

Dressing of the collector

1. Machine the running surface of the collector using a sharp hard metal cutting tool and minimum cutting rate
Cutting speed 250 - 350 m/min
2. If necessary, remove insulation between the collector bars as shown in figure 5:
 - The insulation between the collector bars must be milled or sawn out up to 1.0 ± 0.3 mm
 - Milling width in the centre of the insulation:
0.1 to 0.2 mm wider than the offset of the bars, since residuals at the bar edges would cause sparking and increased wear of the carbon brushes
 - Break collector bar edges slightly under 605 to 905 after milling
3. Check the surface roughness of the bar, since carbon brushes tend to vibrate on very smooth running surfaces which were "polished" using diamonds:
 - A surface roughness between 1.6 mm and 4 mm is permissible
 - When the surface roughness is less: Roughen the bar surface using fine abrasive paper or a fine grindstone to accelerate the formation of patina
4. Use a brush to clean the insulation slots and blow out using compressed air

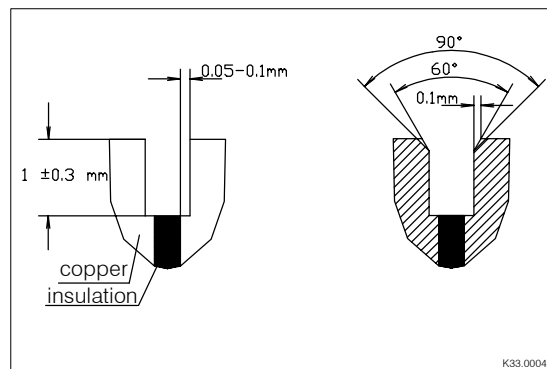

Fig. 5: Milling of the bar insulation at the collector

7.4 Recognition of incorrect operating conditions

The function of the collector and the carbon brushes is influenced by many factors. For example humidity, pollutants in the air in the form of gases, oil or solvent spray etc. as well as a very low temperature of the cooling air, low loads over a long time or vibrations acting on the motor are decisive factors for the commutation and wear of collector and carbon brushes.

A prerequisite for a good function of the carbon brushes is the right choice of the brush material and the correct total cross-section of the carbon brushes of each pole, which must be perfectly adapted to the

motor and the operating conditions of the motor.

Lenze have a long experience in manufacturing motors and selecting optimum carbon brushes. For special operating / ambient conditions the brush material and the number of carbon brushes can be adapted for an optimum wear.

Before selecting another type of carbon brushes, always contact the Lenze Service.

In the following, some troubles, possible causes and measures to improve the commutation and the wear are listed:

Fault	Cause	Remedy
Sparking, increased brush wear, black, coarse spots on the collector surface	Penetration of oil or oil spray	Avoid penetration of oil into the collector area by sealing
		Remove pollutions
		Slightly grind the collector and thoroughly clean carbon brushes
Sparking, chatter marks on collector and carbon brush running surfaces	Solid dust particles under the carbon brushes cause chatter marks	Where necessary, ensure efficient protection against dust using filter elements
		Supply motor with clean cooling air via a tube system
Sparking, collector surface has the colour of copper, increased wear	Formation of patina impossible because of very dry air	Increase humidity by air-conditioning of the operating rooms or by other measures
Insufficient or missing patina, run-in marks at the collector	Temperature of the collector surface and the carbon brushes too low for the formation of patina	Increase ambient temperature and thus the cooling air temperature
	Very low cooling air temperature or motor operation with a considerably lower load current than the rated current over a long time	Reduce carbon brushes according to the load Contact the Lenze Service
Strong sparking, blue or green lights, burns at the bar edges and chipping at the edges of the carbon brushes	High motor overload	Reduce motor load
		Check field supply, measure armature current and adapt to the rated current
Sparking, excessive wear of carbon brushes, collector with clear chatter marks	Operation in rooms with chemically polluted atmosphere	Supply motor with clean cooling air using suitable filter elements or supply of external fresh air
Sparking, burnings at the collector, increased wear	Insufficient contact between carbon brushes and collector	Clean collector in regular intervals
	Acumulation of carbon dust and other pollutants	Check if carbon brushes can easily slide in the brush holders
	Missing pressure	Ensure easy sliding of the carbon brushes with continuing wear
	Reduction of the pressure by high accelerations	Fit stronger springs in the motor

7.5 Waste disposal of the product

- △ Note: Use raw material for recycling
Separate waste disposal according to the different materials:

- **B-side attachments:**
See suitable operating instructions



- **Motor**

A-side endshield:	Aluminium for MGXQK 063-32
	Aluminium diecast for MGXRK 090 - 112
	Others: grey cast iron
Cover sheets:	Steel sheet (sometimes zinc coated)
B-side endshield:	Aluminium for MGXQK 063-32
	Aluminium diecast for MGXRK 090 - 112
	Others: grey cast iron
Brush yoke:	Polyamide P46 glass-fibre reinforced
Carbon holder:	Brass
Carbon brushes:	Carbon, graphite, copper,
	Sometimes synthetic resin
Wires:	Copper with EVA sheath
Tubes:	Glass fibre tube with enamelled polyurethane
Tightening strap:	Steel sheet (zinc coated) with rubber
	(for MGXRK motors)
Cover sheets:	Steel sheet (sometimes zinc coated)
	(for MGXQU and MGXQK motors)
Housing:	Steel for MGXQK 063-32
	Aluminium diecast for MGXRK 090 - 112
	Grey cast for MGXRK 132 - 160
Laminated sheets:	Dynamo sheet
Winding:	Enamelled copper wire
Insulation:	Polyamide, epoxy resin, paper
Terminal box:	Grey cast for MGXRK 132 - 160
	Polyester glass fibre reinforced for
	MGXQU / MGXQK 160
	Others: aluminium diecast
Terminal board:	Polyester glass fibre reinforced
Seals:	NBR or paper
Rotor shaft:	
Shaft:	Steel
Collector:	Copper, steel, phenole resin
Bearings, screws, washers, nuts:	Steel

8. Spare parts

8.1 Spare parts lists

• Roller bearings

Motor type	A-side		B-side	
	normal bearing Type Part no.	reinforced bearing Type Part no.	normal bearing Type Part no.	reinforced bearing Type Part no.
MGXRK 090-22	6205-2RSR-C3 333 043	NU205ECP 333 304	6205-2RSR-C3 333 043	6205-2RSR 333 352
MGXRK 100-22	6206-2RSR-C3 333 112	NU206ECP 311 490	6206-2RSR-C3 333 112	6206-2RSR 333 111
MGXRK 112-22	6306-2RSR-C3 333 204	NU306ECP 311 488	6206-2RSR-C3 333 112	6206-2RSR 333 111
MGXRK 132-22	6308-2RSR-C3 333 109	NU308ECP 311 489	6308-2RSR-C3 333 109	6308-2RSR 333 106
MGXRK 160-32	6310-2RSR-C3 333 205	NU310ECP 330 868	6309-2RSR-C3 333 110	6309-2RSR 333 105
MGXQU 080-12	6305-2RSR-C3 333 203	NU305ECP 369 136	6205-2RSR-C3 333 043	6205-2RSR 333 352
MGXQU 080-22	6305-2RSR-C3 333 203	NU305ECP 369 136	6205-2RSR-C3 333 043	6205-2RSR 333 352
MGXQU 100-22	6306-2RSR-C3 333 204	NU306ECP 311 488	6206-2RSR-C3 333 112	6206-2RSR 333 111
MGXQU 112-12	6308-2RSR-C3 333 109	NU308ECP 311 489	6307-2RSR-C3 333 108	6307-2RSR 333 107
MGXQU 112-22	6308-2RSR-C3 333 109	NU308ECP 311 489	6307-2RSR-C3 333 108	6307-2RSR 333 107
MGXQU 132-32	6308-2RSR-C3 333 109	NU308ECP 311 489	6308-2RSR-C3 333 109	6308-2RSR 333 106
MGXQU/K 160-22	6312-2RSR-C3 334 612	NU312ECP 336 681	6312-2RSR-C3 334 612	6312-2RSR 336 682
MGXQU/K 160-32	6312-2RSR-C3 334 612	NU312ECP 336 681	6312-2RSR-C3 334 612	6312-2RSR 336 682
MGXQK 063-32	6204-2RSR-C3 332 379	---	6204-2RSRC3 332 379	---
MGXQK 100-22	6306-2RSR-C3 333 204	NU306ECP 311 488	6206-2RSR-C3 333 112	6206-2RSR 333 111
MGXQK 100-32	6306-2RSR-C3 333 204	NU306ECP 311 488	6206-2RSR-C3 333 112	6206-2RSR 333 111

• Spare parts list carbon brushes and brush yokes

Motor type	B-side			Time
	Brush yoke	Carbon brushes		
	Part no.	Dimensions	No.	
MGXRK 090-22	323 436	6.3x12.5x20 328 873	4	before 31.01.94
	348 917	6.3x12.5x20 328 873	4	as from 01.02.94
MGXRK 100-22	326 542	8x12.5x20 328 876	4	before 28.02.89
	323 437	8x12.5x20 328 875	4	as from 01.03.89
MGXRK 112-22 up to 20 (A)	320 388	8x12.5x20 328 876	4	
as from 20 (A)	323 319	8x10x20 328 874	8	
MGXRK 132-22 up to 27 (A)	310 037	10x16x25 328 879	4	
as from 27 (A)	320 383	10x12.5x20 328 878	8	
MGXRK 160-32 up to 32 A	328 839	10x16x32 329 624	8	
as from 32 A	328 839	10x16x32 329 624	4	
MGXQU 080-12	337 795	8x16x25 337 802	4	
MGXQU 080-22	326 542	8x12.5x20 328 876	4	before 28.02.89
	323 437	8x12.5x20 328 875	4	as from 01.03.89 before 31.07.92
	337 795	8x16x25 337 802	4	as from 01.08.92
MGXQU 100-22	329 076	10x12.5x25 329 176	8	before 31.07.92
up to 32 (A)	341 788	10x16x25 337 801	4	as from 01.08.92
as from 32 (A)	337 796	10x16x25 337 801	8	as from 01.08.92
MGXQU 112-12 up to 32 A	347 131	10x16x25 347 135	4	
as from 32 A	347 131	10x16x25 347 135	8	
MGXQU 112-22 up to 25 A	320 383	10x12.5x20 328 878	4	before 31.12.92
as from 25 A	320 383	10x12.5x20 328 878	8	before 31.12.92
up to 32 A	347 131	10x16x25 347 135	4	as from 01.01.93
from 32 A	347 131	10x16x25 347 135	8	as from 01.01.93
MGXQU 132-32 up to 90 (A)	329 328	10x20x32 329 393	8	
90-120 (A)	332 197	12.5x20x32 328 880	8	
	332 197	12.5x20x32 330 880	8	

Motor type	B-side			Time
	Brush yoke	Carbon brushes		
	Part no.	Dimensions	No.	
MGXQU/K 160-22	333 609	12.5x25x32 334 607	4	
up to 70 (A)	333 609	12.5x25x32 334 607	8	
up to 120 (A)	333 609	12.5x25x32 334 607	12	
from 120 (A)	333 609	12.5x25x32Z w 336 699	12	
MGXQU/K 160-32	333 609	12.5x25x32 334 607	4	
up to 70 (A)	333 609	12.5x25x32 334 607	8	
up to 120 (A)	333 609	12.5x25x32 334 607	12	
from 120 (A)	333 609	12.5x25x32Z w 336 699	12	
MGXQK 063-32	333 703	6.3x16x20 333 780	4	
MGXQK 100-22	329 669	10x12.5x25 329 765	8	
MGXQK 100-32 up to 27 (A)	329 076	10x12.5x25 329 176	4	
from 27 (A)	329 076	10x12.5x25 329 176	8	

8.2 Ordering example for spare parts

When ordering spare parts, please indicate at least:

- Designation of the spare parts
- Required number of pieces
- Data of the motor nameplate (chapter 4.4):
 - Motor type
 - Commission number (K.- Nr.)
 - Motor number (Mot.- Nr.)
 - Rated current (I_N)

When indicating the designation of the spare part, please observe a possible special carbon brushes of your motor.

Recommendation: Take a carbon brush out of your motor and check whether it is a standard part according to the spare part list above or whether it is a special carbon brush.

Ordering example for a set of carbon brushes of a motor type MGFRKBT132-22 with $I_N=28.0$ A

Lenze Lenze GmbH & Co KG Hans-Lenze-Straße 1, D-31855 Aerzen			
G	Mot.	Typ	MGFRKBT132-22 IP
K	4/39610	Nr.	0257181 VDE 0530
	V	A	min ⁻¹ kW
	V	28,0	A Err
⊕ Isol.Kl.			⊕

T374595

- Carbon brush part no. 328 878
- 8 pieces
- Comm no: 4 / 39610
- Motor no.: 0257181
- I_N : 28,0 A

Lenze GmbH & Co KG, Postfach 10 13 52, D-31 763 Hameln, Standort : Gross Berkel, Hans-Lenze Straße 1, D-31 855 Aerzen
Telefon (0 51 54) 82-0, Telefax (0 51 54) 40 40, Telefax Kundendienst/Service (0 51 54)82 2335